

OVERALL SIZE
455mm x 1217mm

----- **DISPLAY AREA**
403mm x 1165mm

DELIVERY DEADLINE AND POSTING CYCLE

Posters must be produced to the exact specification set out below and delivered 14 calendar days before the 'In-charge' date of the campaign. Campaigns are then posted on a 6 calendar day cycle (excluding Bank Holidays) which commences before the 'In-charge' date.

Please note: CBS Outdoor is not liable for compensation claims against any campaign where posters have been received after the delivery deadline. All posters received after the delivery deadline will not be posted until the next available posting cycle for this site type.

COPY APPROVAL

Before posting can commence, every Bus campaign must be submitted to CBS Outdoor for copy approval. This is to ensure that the Codes of Practice outlined by our franchise partners are being upheld. See **Copy Approval**.

BARCODING

Every campaign must have the appropriate barcode printed on all posters. See **Barcoding of Bus and Tram Campaigns**.

DISPLAY AREA

For all site types that are fixed into frames, the specification will give the Overall Size and the Display Area. Please keep all important text and images within the Display Area but feel free to bleed the background colours/images up to the Overall Size. Please be aware that if an artwork has text that has been created to the Display Area it will butt-up to the frame. If this is not the desired effect then please move the text even further inside the Display Area.

MATERIALS

Posters printed on any photographic or reflective materials cannot be accepted. CBS Outdoor will also refuse to accept any poster produced with Pre-spaced Vinyl Cut Lettering.

Please use 100 micron removable self-adhesive vinyl of the following makes only as they have been tested and approved by CBS Outdoor:

MACTAC MACAL 8129/MR980, RITRAMA RI.145/100 VM Removable, FASSON FASCAL Superscreen 100 and ORACAL 1665 Bus Vinyl.

Permanent adhesives and materials with unmarked backing sheets will not be accepted.

INKS

When screen-printing onto any of the approved vinyls, CBS Outdoor recommends the following ink ranges, all of which are suitable for transport advertising:

UV CURING INKS:

SUN CHEMICALS – Harmony HRN series, Vioflex 4000 series, Solarsilk SLK series and Synergy SRG series.

SERICOL – Uviplast HiFlex ES Trichromatics, Uvispeed Multiflash UZ and Aquaspeed Display VQ/YZ.

SMALL PRODUCTS – 5060 Series.

SOLVENT-BASED INKS:

SUN CHEMICALS – Vynaglaze 4700 series and Flexijet 4800 series.

SERICOL – Plastijet TL Trichromatics and Plastijet XG.

INKS (Continued)

Please note: Variations in the compatibility of ink, vinyl and drying method can cause a reduction in the vinyl's durability and may cause the vinyl to become brittle, therefore each ink, vinyl and drying combination should be thoroughly tested for suitability before commencing with poster production. For more advice please contact the vinyl and ink manufacturers.

CBS Outdoor will not accept responsibility for vinyl failures that may occur due to ink, vinyl or drying incompatibilities.

DIGITAL PRINTING

If you intend to digitally-print your posters, please contact the CBS Outdoor Production department on 020 7482 3000 for further advice.

PROTECTIVE FINISH

The rear of a bus takes the most punishment from bus-wash brushes, therefore CBS Outdoor insists that a clear machine or UV varnish **must** be applied to the poster surface. For campaigns of longer than 12 weeks, an over-laminate **must** be applied to the printed poster to protect the image.

CBS OUTDOOR POSTER DESPATCH FORM

The CBS Outdoor Poster Despatch Form will give all the relevant information for each campaign with regard to quantities, collation details and delivery addresses. If you require a copy, please contact the CBS Outdoor Customer Service department on 020 7482 3000 and quote the campaign reference.

SPARE POSTERS

CBS Outdoor will always require additional 'spare' posters to refurbish campaigns. The quantities shown on the CBS Outdoor Poster Despatch Form will include the required number of spares.

TRIMMING

All posters must be trimmed to the exact Overall Size.

POSTER COLLATION AND PACKING

Posters will need to be delivered in a combination of 'rolled' and 'flat'.

Rolled: Please deliver posters rolled with the design out and wrapped in packages of no more than 30. Please ensure that the edges are fully protected to avoid damage in transit. Folded vinyls cannot be accepted.

Flat: Please deliver posters flat on a pallet. A tab must be inserted between every 50th vinyl. The pallet must be bound securely, ensuring the poster edges are fully protected to avoid damage in transit.

DELIVERY NOTES

Every consignment of posters delivered must have a Delivery Note attached indicating the advertiser, the number of designs, a title for each of the designs and the quantity of each design.

POSTER DELIVERY ADDRESSES

CBS Outdoor is not responsible for the delivery of your posters. Please contact CBS Outdoor Customer Service on 020 7482 3000 for the Poster Despatch Form.

CHANGES OF DESIGN

For campaigns lasting longer than 4 weeks a free, full or partial change of design will be provided during each succeeding 4 weeks.

Charges for more frequent changes of design are available on request.

Exact dates for changes of design are subject to posting cycle workload. Please contact CBS Outdoor Customer Service on 020 7482 3000 for more information.

DISPOSAL OF SPARE POSTERS

Please notify CBS Outdoor Customer Service in writing if you wish to retain spare posters after a campaign has ended. A small storage charge will be made. Otherwise posters will be disposed of 10 days after the campaign has ended.

CBS Outdoor, Camden Wharf, 28 Jamestown Road, Camden, London NW1 7BY.

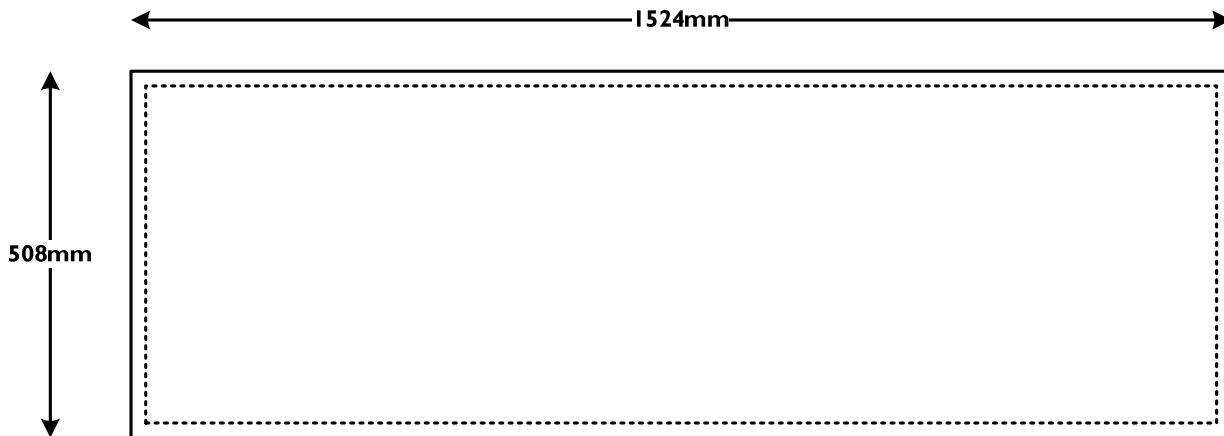

OVERALL SIZE
508mm x 1524mm

----- **DISPLAY AREA**
456mm x 1472mm

DELIVERY DEADLINE AND POSTING CYCLE

Posters must be produced to the exact specification set out below and delivered 4 calendar days before the 'In-charge' date of the campaign. Campaigns are then posted on a 6 calendar day cycle (excluding Bank Holidays) which commences before the 'In-charge' date.

Please note: CBS Outdoor is not liable for compensation claims against any campaign where posters have been received after the delivery deadline. All posters received after the delivery deadline will not be posted until the next available posting cycle for this site type.

COPY APPROVAL

Before posting can commence, every Bus campaign must be submitted to CBS Outdoor for copy approval. This is to ensure that the Codes of Practice outlined by our franchise partners are being upheld. See **Copy Approval**.

BARCODING

Every campaign must have the appropriate barcode printed on all posters. See **Barcoding of Bus and Tram Campaigns**.

DISPLAY AREA

For all site types that are fixed into frames, the specification will give the Overall Size and the Display Area. Please keep all important text and images within the Display Area but feel free to bleed the background colours/images up to the Overall Size. Please be aware that if an artwork has text that has been created to the Display Area it will butt-up to the frame. If this is not the desired effect then please move the text even further inside the Display Area.

Please note: CBS Outdoor strongly recommends that you do not use the frame as a 'cropping device' for corporate logos as 100% accuracy cannot be guaranteed due to the fact that not all buses are framed.

MATERIALS - WATER-RESISTANT BOARD

Please use 1370 micron CBS Outdoor approved **ALL WEATHER BOARD**.

Available from Pyramid Display Materials:

Gateshead – 0191 487 7130 – gatesheadsales@pyramid-display.co.uk Manchester – 0161 872 5666 – colin.doherty@pyramid-display.co.uk

Birmingham – 0121 333 5947 – mark.spiers@pyramid-display.co.uk Technical Advice (Alan Aird) – 0797 422 7323 – alan.aird@pyramid-display.co.uk

PROTECTIVE FINISH – WATER-RESISTANT BOARD

CBS Outdoor insists that a clear machine or UV varnish must be applied to the poster.

MATERIALS - VINYL

Posters printed on any photographic or reflective materials cannot be accepted. CBS Outdoor will also refuse to accept any poster produced with Pre-spaced Vinyl Cut Lettering.

Please use 100 micron removable self-adhesive vinyl of the following makes only as they have been tested and approved by CBS Outdoor:

MACTAC MACAL 8129/MR980, 8129/MR180, RITRAMA RI.145/100 VM Removable, FASSON FASCAL Superscreen 100 and ORACAL 1665 Bus Vinyl.

Permanent adhesives and materials with unmarked backing sheets will not be accepted.

PROTECTIVE FINISH - VINYL

The rear of a bus takes the most punishment from bus-wash brushes, therefore CBS Outdoor insists that a clear machine or UV varnish **must** be applied to the poster surface. For campaigns of longer than 12 weeks, an over-laminate **must** be applied to the printed poster to protect the image.

INKS

When screen-printing onto any of the approved vinyls, CBS Outdoor recommends the following ink ranges, all of which are suitable for transport advertising:

UV CURING INKS: SUN CHEMICALS – Harmony HRN series, Vioflex 4000 series, Solarsilk SLK series and Synergy SRG series.

SERICOL – Uviplast HiFlex ES Trichromatics, Uvispeed Multiflash UZ and Aquaspeed Display VQ/YZ. **SMALL PRODUCTS** – 5060 Series.

INKS Continued

SOLVENT-BASED INKS: **SUN CHEMICALS** – Vynaglaze 4700 series and Flexijet 4800 series. **SERICOL** – Plastijet TL Trichromatics and Plastijet XG.

Please note: Variations in the compatibility of ink, vinyl and drying method can cause a reduction in the vinyl's durability and may cause the vinyl to become brittle, therefore each ink, vinyl and drying combination should be thoroughly tested for suitability before commencing with poster production. For more advice please contact the vinyl and ink manufacturers.

CBS Outdoor will not accept responsibility for vinyl failures that may occur due to ink, vinyl or drying incompatibilities.

DIGITAL PRINTING

If you intend to digitally-print your posters, please contact the CBS Outdoor Production department on 020 7482 3000 for further advice.

CBS OUTDOOR POSTER DESPATCH FORM

The CBS Outdoor Poster Despatch Form will give all the relevant information for each campaign with regard to quantities, collation details and delivery addresses. If you require a copy, please contact the CBS Outdoor Customer Service department on 020 7482 3000 and quote the campaign reference.

SPARE POSTERS

CBS Outdoor will always require additional 'spare' posters to refurbish campaigns. The quantities shown on the CBS Outdoor Poster Despatch Form will include the required number of spares.

TRIMMING

All posters must be trimmed to the exact Overall Size.

POSTER COLLATION AND PACKING

Posters will need to be delivered in a combination of 'rolled' and 'flat'.

Rolled: Please deliver posters rolled with the design out and wrapped in packages of no more than 30. Please ensure that the edges are fully protected to avoid damage in transit. Folded vinyls cannot be accepted.

Flat: Please deliver posters flat on a pallet. A tab must be inserted between every 50th vinyl. The pallet must be bound securely, ensuring the poster edges are fully protected to avoid damage in transit.

QUALITY ASSURANCE DOCUMENTATION

All deliveries will require documentation giving details of Quality Assurance Checks. This must clearly identify the following information: Suppliers name, campaign reference(s), print method, ink & varnish details and drying method. CBS Outdoor will also require the name of the person who carried out the Quality Assurance Checks for that particular consignment.

DELIVERY NOTES

Every consignment of posters delivered must have a Delivery Note attached indicating the advertiser, the number of designs, a title for each of the designs and the quantity of each design.

POSTER DELIVERY ADDRESSES

CBS Outdoor is not responsible for the delivery of your posters. Please contact CBS Outdoor Customer Service on 020 7482 3000 for the Poster Despatch Form.

CHANGES OF DESIGN

For campaigns lasting longer than 4 weeks a free, full or partial change of design will be provided during each succeeding 4 weeks.

Charges for more frequent changes of design are available on request.

Exact dates for changes of design are subject to posting cycle workload. Please contact CBS Outdoor Customer Service on 020 7482 3000 for more information.

DISPOSAL OF SPARE POSTERS

Please notify CBS Outdoor Customer Service in writing if you wish to retain spare posters after a campaign has ended. A small storage charge will be made. Otherwise posters will be disposed of 10 days after the campaign has ended.

CBS Outdoor, Camden Wharf, 28 Jamestown Road, Camden, London NW1 7BY.

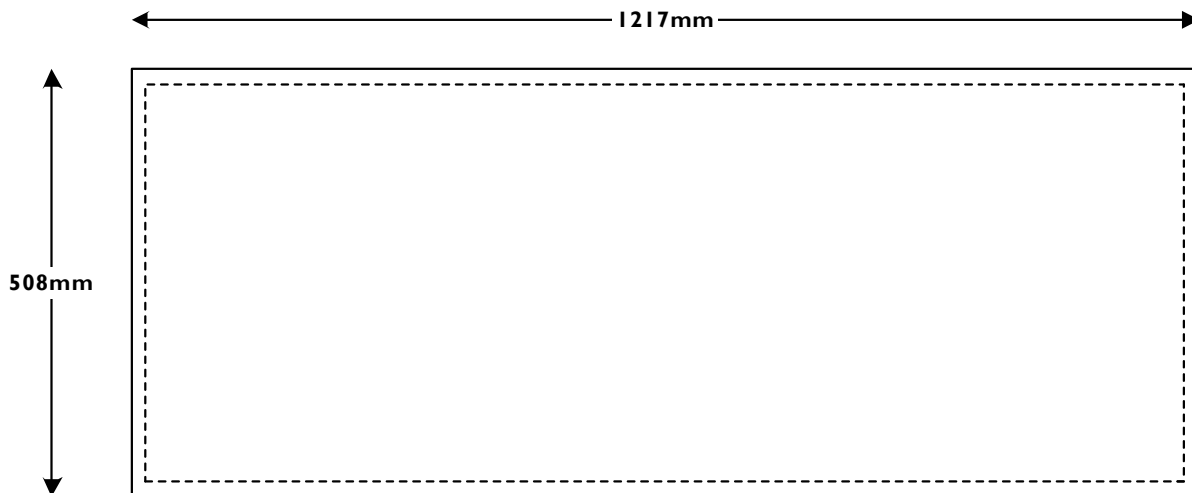

OVERALL SIZE
508mm x 1217mm

----- **DISPLAY AREA**
456mm x 1165mm

DELIVERY DEADLINE AND POSTING CYCLE

Posters must be produced to the exact specification set out below and delivered 14 calendar days before the 'In-charge' date of the campaign. Campaigns are then posted on a 6 calendar day cycle (excluding Bank Holidays) which commences before the 'In-charge' date.

Please note: CBS Outdoor is not liable for compensation claims against any campaign where posters have been received after the delivery deadline. All posters received after the delivery deadline will not be posted until the next available posting cycle for this site type.

COPY APPROVAL

Before posting can commence, every bus campaign must be submitted to CBS Outdoor for copy approval. This is to ensure that the Codes of Practice outlined by our franchise partners are being upheld. See **Copy Approval**.

BARCODING

Every campaign must have the appropriate barcode printed on all posters. See **Barcoding of Bus and Tram Campaigns**.

DISPLAY AREA

For all site types that are fixed into frames, the specification will give the Overall Size and the Display Area. Please keep all important text and images within the Display Area but feel free to bleed the background colours/images up to the Overall Size. Please be aware that if an artwork has text that has been created to the Display Area it will butt-up to the frame. If this is not the desired effect then please move the text even further inside the Display Area.

MATERIALS

Posters printed on any photographic or reflective materials cannot be accepted. CBS Outdoor will also refuse to accept any poster produced with Pre-spaced Vinyl Cut Lettering.

Please use 100 micron removable self-adhesive vinyl of the following makes only as they have been tested and approved by CBS Outdoor:

MACTAC MACAL 8129/MR980, RITRAMA RI.145/100 VM Removable, FASSON FASCAL Superscreen 100 and ORACAL 1665 Bus Vinyl.

Permanent adhesives and materials with unmarked backing sheets will not be accepted.

INKS

When screen-printing onto any of the approved vinyls, CBS Outdoor recommends the following ink ranges, all of which are suitable for transport advertising:

UV CURING INKS:

SUN CHEMICALS – Harmony HRN series, Vioflex 4000 series, Solarsilk SLK series and Synergy SRG series.

SERICOL – Uviplast HiFlex ES Trichromatics, Uvispeed Multiflash UZ and Aquaspeed Display VQ/YZ.

SMALL PRODUCTS – 5060 Series.

SOLVENT-BASED INKS:

SUN CHEMICALS – Vynaglaze 4700 series and Flexijet 4800 series.

SERICOL – Plastijet TL Trichromatics and Plastijet XG.

INKS (Continued)

Please note: Variations in the compatibility of ink, vinyl and drying method can cause a reduction in the vinyl's durability and may cause the vinyl to become brittle, therefore each ink, vinyl and drying combination should be thoroughly tested for suitability before commencing with poster production. For more advice please contact the vinyl and ink manufacturers.

CBS Outdoor will not accept responsibility for vinyl failures that may occur due to ink, vinyl or drying incompatibilities.

DIGITAL PRINTING

If you intend to digitally-print your posters, please contact the CBS Outdoor Production department on 020 7482 3000 for further advice.

PROTECTIVE FINISH

The rear of a bus takes the most punishment from bus-wash brushes, therefore CBS Outdoor insists that a clear machine or UV varnish **must** be applied to the poster surface. For campaigns of longer than 12 weeks, an over-laminate **must** be applied to the printed poster to protect the image.

CBS OUTDOOR POSTER DESPATCH FORM

The CBS Outdoor Poster Despatch Form will give all the relevant information for each campaign with regard to quantities, collation details and delivery addresses. If you require a copy, please contact the CBS Outdoor Customer Service department on 020 7482 3000 and quote the campaign reference.

SPARE POSTERS

CBS Outdoor will always require additional 'spare' posters to refurbish campaigns. The quantities shown on the CBS Outdoor Poster Despatch Form will include the required number of spares.

TRIMMING

All posters must be trimmed to the exact Overall Size.

POSTER COLLATION AND PACKING

Posters will need to be delivered in a combination of 'rolled' and 'flat'.

Rolled: Please deliver posters rolled with the design out and wrapped in packages of no more than 30. Please ensure that the edges are fully protected to avoid damage in transit. Folded vinyls cannot be accepted.

Flat: Please deliver posters flat on a pallet. A tab must be inserted between every 50th vinyl. The pallet must be bound securely, ensuring the poster edges are fully protected to avoid damage in transit.

DELIVERY NOTES

Every consignment of posters delivered must have a Delivery Note attached indicating the advertiser, the number of designs, a title for each of the designs and the quantity of each design.

POSTER DELIVERY ADDRESSES

CBS Outdoor is not responsible for the delivery of your posters. Please contact CBS Outdoor Customer Service on 020 7482 3000 for the Poster Despatch Form.

CHANGES OF DESIGN

For campaigns lasting longer than 4 weeks a free, full or partial change of design will be provided during each succeeding 4 weeks.

Charges for more frequent changes of design are available on request.

Exact dates for changes of design are subject to posting cycle workload. Please contact CBS Outdoor Customer Service on 020 7482 3000 for more information.

DISPOSAL OF SPARE POSTERS

Please notify CBS Outdoor Customer Service in writing if you wish to retain spare posters after a campaign has ended. A small storage charge will be made. Otherwise posters will be disposed of 10 days after the campaign has ended.

CBS Outdoor, Camden Wharf, 28 Jamestown Road, Camden, London NW1 7BY.

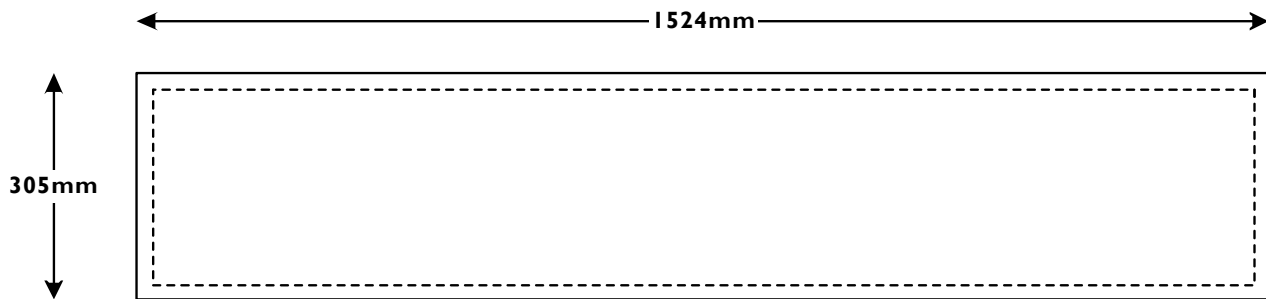

OVERALL SIZE
305mm x 1524mm

----- **DISPLAY AREA**
253mm x 1472mm

DELIVERY DEADLINE AND POSTING CYCLE

Posters must be produced to the exact specification set out below and delivered 14 calendar days before the ‘In-charge’ date of the campaign. Campaigns are then posted on a 6 calendar day cycle (excluding Bank Holidays) which commences before the ‘In-charge’ date.

Please note: CBS Outdoor is not liable for compensation claims against any campaign where posters have been received after the delivery deadline. All posters received after the delivery deadline will not be posted until the next available posting cycle for this site type.

COPY APPROVAL

Before posting can commence, every Bus campaign must be submitted to CBS Outdoor for copy approval. This is to ensure that the Codes of Practice outlined by our franchise partners are being upheld. See **Copy Approval**.

BARCODING

Every campaign must have the appropriate barcode printed on all posters. See **Barcoding of Bus and Tram Campaigns**.

DISPLAY AREA

For all site types that are fixed into frames, the specification will give the Overall Size and the Display Area. Please keep all important text and images within the Display Area but feel free to bleed the background colours/images up to the Overall Size. Please be aware that if an artwork has text that has been created to the Display Area it will butt-up to the frame. If this is not the desired effect then please move the text even further inside the Display Area.

Please note: CBS Outdoor strongly recommends that you do not use the frame as a ‘cropping device’ for corporate logos as 100% accuracy cannot be guaranteed due to the fact that not all buses are framed.

MATERIALS

Posters printed on any photographic or reflective materials cannot be accepted. CBS Outdoor will also refuse to accept any poster produced with Pre-spaced Vinyl Cut Lettering.

Please use 100 micron removable self-adhesive vinyl of the following makes only as they have been tested and approved by CBS Outdoor:
MACTAC MACAL 8129/MR980, 8129/MR180, RITRAMA R1.145/100 VM Removable, FASSON FASCAL Superscreen 100 and ORACAL 1665 Bus Vinyl.

Permanent adhesives and materials with unmarked backing sheets will not be accepted.

INKS

When screen-printing onto any of the approved vinyls, CBS Outdoor recommends the following ink ranges, all of which are suitable for transport advertising:

UV CURING INKS:

SUN CHEMICALS – Harmony HRN series, Vioflex 4000 series, Solarsilk SLK series and Synergy SRG series. **SERICOL** – Uviplast HiFlex ES Trichromatics, Uvispeed Multiflash UZ and Aquaspeed Display VQ/YZ. **SMALL PRODUCTS** – 5060 Series.

SOLVENT-BASED INKS:

SUN CHEMICALS – Vynaglaze 4700 series and Flexijet 4800 series. **SERICOL** – Plastijet TL Trichromatics and Plastijet XG.

Please note: Variations in the compatibility of ink, vinyl and drying method can cause a reduction in the vinyl’s durability and may cause the vinyl to become brittle, therefore each ink, vinyl and drying combination should be thoroughly tested for suitability before commencing with poster production. For more advice please contact the vinyl and ink manufacturers.

CBS Outdoor will not accept responsibility for vinyl failures that may occur due to ink, vinyl or drying incompatibilities.

DIGITAL PRINTING

If you intend to digitally-print your posters, please contact the CBS Outdoor Production department on 020 7482 3000 for further advice.

PROTECTIVE FINISH

The rear of a bus takes the most punishment from bus-wash brushes, therefore CBS Outdoor insists that a clear machine or UV varnish **must** be applied to the poster surface. For campaigns of longer than 12 weeks, an over-laminate **must** be applied to the printed poster to protect the image.

CBS OUTDOOR POSTER DESPATCH FORM

The CBS Outdoor Poster Despatch Form will give all the relevant information for each campaign with regard to quantities, collation details and delivery addresses. If you require a copy, please contact the CBS Outdoor Customer Service department on 020 7482 3000 and quote the campaign reference.

SPARE POSTERS

CBS Outdoor will always require additional 'spare' posters to refurbish campaigns. The quantities shown on the CBS Outdoor Poster Despatch Form will include the required number of spares.

TRIMMING

All posters must be trimmed to the exact Overall Size.

POSTER COLLATION AND PACKING

Posters will need to be delivered in a combination of 'rolled' and 'flat'.

Rolled: Please deliver posters rolled with the design out and wrapped in packages of no more than 30. Please ensure that the edges are fully protected to avoid damage in transit. Folded vinyls cannot be accepted.

Flat: Please deliver posters flat on a pallet. A tab must be inserted between every 50th vinyl. The pallet must be bound securely, ensuring the poster edges are fully protected to avoid damage in transit.

QUALITY ASSURANCE DOCUMENTATION

All deliveries will require documentation giving details of Quality Assurance Checks. This must clearly identify the following information: campaign reference(s), print method, ink details and drying method. CBS Outdoor will also require the name of the person who carried out the Quality Assurance Checks for that particular consignment.

DELIVERY NOTES

Every consignment of posters delivered must have a Delivery Note attached indicating the advertiser, the number of designs, a title for each of the designs and the quantity of each design.

POSTER DELIVERY ADDRESSES

CBS Outdoor is not responsible for the delivery of your posters. Please contact CBS Outdoor Customer Service on 020 7482 3000 for the Poster Despatch Form.

CHANGES OF DESIGN

For campaigns lasting longer than 4 weeks a free, full or partial change of design will be provided during each succeeding 4 weeks.

Charges for more frequent changes of design are available on request.

Exact dates for changes of design are subject to posting cycle workload. Please contact CBS Outdoor Customer Service on 020 7482 3000 for more information.

DISPOSAL OF SPARE POSTER

Please notify CBS Outdoor Customer Service in writing if you wish to retain spare posters after a campaign has ended. A small storage charge will be made. Otherwise posters will be disposed of 10 days after the campaign has ended.

CBS Outdoor, Camden Wharf, 28 Jamestown Road, Camden, London NW1 7BY.

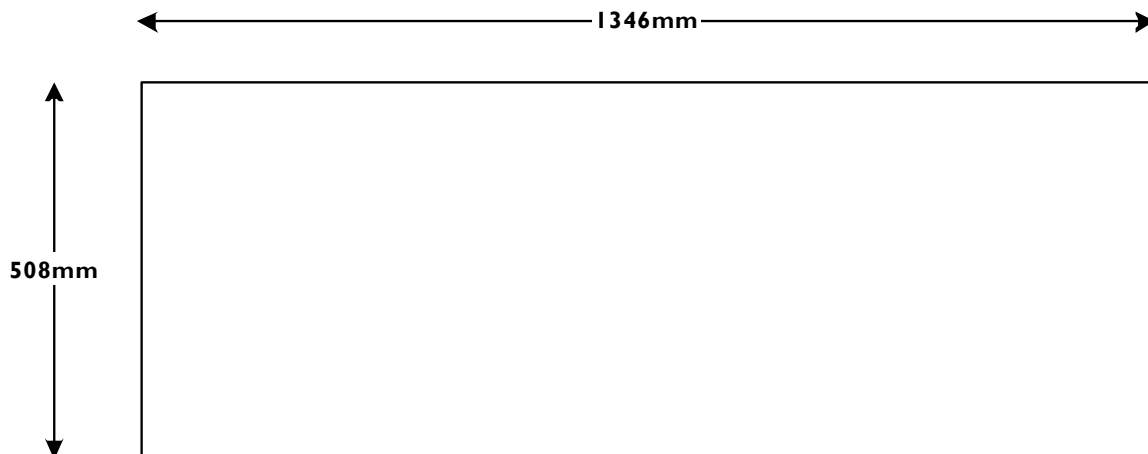

DELIVERY DEADLINE AND POSTING CYCLE

Posters must be produced to the exact specification set out below and delivered 14 calendar days before the 'In-charge' date of the campaign. Campaigns are then posted on a 6 calendar day cycle (excluding Bank Holidays) which commences before the 'In-charge' date.

Please note: CBS Outdoor is not liable for compensation claims against any campaign where posters have been received after the delivery deadline. All posters received after the delivery deadline will not be posted until the next available posting cycle for this site type.

COPY APPROVAL

Before posting can commence, every Bus campaign must be submitted to CBS Outdoor for copy approval. This is to ensure that the Codes of Practice outlined by our franchise partners are being upheld. See **Copy Approval**.

BARCODING

Every campaign must have the appropriate barcode printed on all posters. See **Barcoding of Bus and Tram Campaigns**.

MATERIALS

Posters printed on any photographic or reflective materials cannot be accepted. CBS Outdoor will also refuse to accept any poster produced with Pre-spaced Vinyl Cut Lettering.

Please use 100 micron removable self-adhesive vinyl of the following makes only as they have been tested and approved by CBS Outdoor:

MACTAC MACAL 8129/MR980, RITRAMA RI.145/100 VM Removable, FASSON FASCAL Superscreen 100 and ORACAL 1665 Bus Vinyl.

Permanent adhesives and materials with unmarked backing sheets will not be accepted.

INKS

When screen-printing onto any of the approved vinyls, CBS Outdoor recommends the following ink ranges, all of which are suitable for transport advertising:

UV CURING INKS:

SUN CHEMICALS – Harmony HRN series, Vioflex 4000 series, Solarsilk SLK series and Synergy SRG series.

SERICOL – Uviplast HiFlex ES Trichromatics, Uvispeed Multiflash UZ and Aquaspeed Display VQ/YZ.

SMALL PRODUCTS – 5060 Series.

SOLVENT-BASED INKS:

SUN CHEMICALS – Vynaglaze 4700 series and Flexijet 4800 series.

SERICOL – Plastijet TL Trichromatics and Plastijet XG.

Please note: Variations in the compatibility of ink, vinyl and drying method can cause a reduction in the vinyl's durability and may cause the vinyl to become brittle, therefore each ink, vinyl and drying combination should be thoroughly tested for suitability before commencing with poster production. For more advice please contact the vinyl and ink manufacturers.

CBS Outdoor will not accept responsibility for vinyl failures that may occur due to ink, vinyl or drying incompatibilities.

DIGITAL PRINTING

If you intend to digitally-print your posters, please contact the CBS Outdoor Production department on 020 7482 3000 for further advice.

PROTECTIVE FINISH

The rear of a bus takes the most punishment from bus-wash brushes, therefore CBS Outdoor insists that a clear machine or UV varnish **must** be applied to the poster surface. For campaigns of longer than 12 weeks, an over-laminate **must** be applied to the printed poster to protect the image.

CBS OUTDOOR POSTER DESPATCH FORM

The CBS Outdoor Poster Despatch Form will give all the relevant information for each campaign with regard to quantities, collation details and delivery addresses. If you require a copy, please contact the CBS Outdoor Customer Service department on 020 7482 3000 and quote the campaign reference.

SPARE POSTERS

CBS Outdoor will always require additional 'spare' posters to refurbish campaigns. The quantities shown on the CBS Outdoor Poster Despatch Form will include the required number of spares.

TRIMMING

All posters must be trimmed to the exact Overall Size.

POSTER COLLATION AND PACKING

Please deliver posters rolled with the design out and wrapped in packages of no more than 30. Please ensure that the edges are fully protected to avoid damage in transit. Folded vinyls cannot be accepted.

DELIVERY NOTES

Every consignment of posters delivered must have a Delivery Note attached indicating the advertiser, the number of designs, a title for each of the designs and the quantity of each design.

POSTER DELIVERY ADDRESSES

CBS Outdoor is not responsible for the delivery of your posters. Please contact CBS Outdoor Customer Service on 020 7482 3000 for the Poster Despatch Form.

CHANGES OF DESIGN

For campaigns lasting longer than 4 weeks a free, full or partial change of design will be provided during each succeeding 4 weeks.

Charges for more frequent changes of design are available on request.

Exact dates for changes of design are subject to posting cycle workload. Please contact CBS Outdoor Customer Service on 020 7482 3000 for more information.

DISPOSAL OF SPARE POSTERS

Please notify CBS Outdoor Customer Service in writing if you wish to retain spare posters after a campaign has ended. A small storage charge will be made. Otherwise posters will be disposed of 10 days after the campaign has ended.

CBS Outdoor, Camden Wharf, 28 Jamestown Road, Camden, London NW1 7BY.

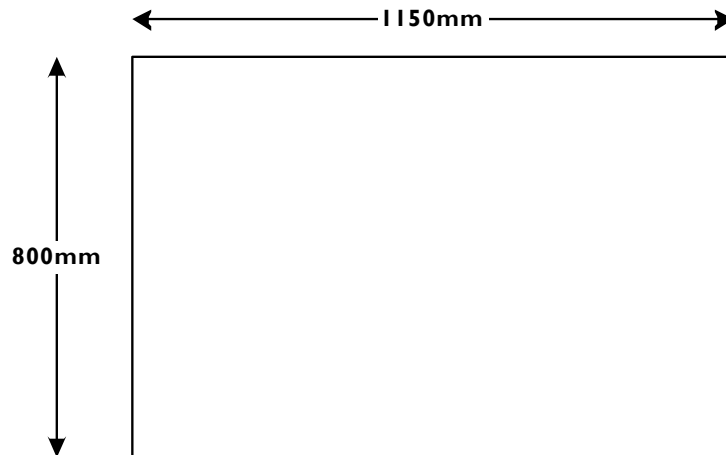

DELIVERY DEADLINE AND POSTING CYCLE

Posters must be produced to the exact specification set out below and delivered 14 calendar days before the 'In-charge' date of the campaign. Campaigns are then posted on a 6 calendar day cycle (excluding Bank Holidays) which commences before the 'In-charge' date.

Please note: CBS Outdoor is not liable for compensation claims against any campaign where posters have been received after the delivery deadline. All posters received after the delivery deadline will not be posted until the next available posting cycle for this site type.

COPY APPROVAL

Before posting can commence, every Bus campaign must be submitted to CBS Outdoor for copy approval. This is to ensure that the Codes of Practice outlined by our franchise partners are being upheld. See **Copy Approval**.

BARCODING

Every campaign must have the appropriate barcode printed on all posters. See **Barcoding of Bus and Tram Campaigns**.

MATERIALS

Posters printed on any photographic or reflective materials cannot be accepted. CBS Outdoor will also refuse to accept any poster produced with Pre-spaced Vinyl Cut Lettering.

Please use 100 micron removable self-adhesive vinyl of the following makes only as they have been tested and approved by CBS Outdoor:
MACTAC MACAL 8129/MR980, RITRAMA RI.145/100 VM Removable, FASSON FASCAL Superscreen 100 and ORACAL 1665 Bus Vinyl.

Permanent adhesives and materials with unmarked backing sheets will not be accepted.

INKS

When screen-printing onto any of the approved vinyls, CBS Outdoor recommends the following ink ranges, all of which are suitable for transport advertising:

UV CURING INKS:

SUN CHEMICALS – Harmony HRN series, Vioflex 4000 series, Solarsilk SLK series and Synergy SRG series.

SERICOL – Uviplast HiFlex ES Trichromatics, Uvispeed Multiflash UZ and Aquaspeed Display VQ/YZ.

SMALL PRODUCTS – 5060 Series.

SOLVENT-BASED INKS:

SUN CHEMICALS – Vynaglaze 4700 series and Flexijet 4800 series.

SERICOL – Plastijet TL Trichromatics and Plastijet XG.

Please note: Variations in the compatibility of ink, vinyl and drying method can cause a reduction in the vinyl's durability and may cause the vinyl to become brittle, therefore each ink, vinyl and drying combination should be thoroughly tested for suitability before commencing with poster production. For more advice please contact the vinyl and ink manufacturers.

CBS Outdoor will not accept responsibility for vinyl failures that may occur due to ink, vinyl or drying incompatibilities.

DIGITAL PRINTING

If you intend to digitally-print your posters, please contact the CBS Outdoor Production department on 020 7482 3000 for further advice..

PROTECTIVE FINISH

The rear of a bus takes the most punishment from bus-wash brushes, therefore CBS Outdoor insists that a clear machine or UV varnish **must** be applied to the poster surface. For campaigns of longer than 12 weeks, an over-laminate **must** be applied to the printed poster to protect the image.

CBS OUTDOOR POSTER DESPATCH FORM

The CBS Outdoor Poster Despatch Form will give all the relevant information for each campaign with regard to quantities, collation details and delivery addresses. If you require a copy, please contact the CBS Outdoor Customer Service department on 020 7482 3000 and quote the campaign reference.

SPARE POSTERS

CBS Outdoor will always require additional 'spare' posters to refurbish campaigns. The quantities shown on the CBS Outdoor Poster Despatch Form will include the required number of spares.

TRIMMING

All posters must be trimmed to the exact Overall Size.

POSTER COLLATION AND PACKING

Please deliver posters rolled with the design out and wrapped in packages of no more than 30. Please ensure that the edges are fully protected to avoid damage in transit. Folded vinyls cannot be accepted.

DELIVERY NOTES

Every consignment of posters delivered must have a Delivery Note attached indicating the advertiser, the number of designs, a title for each of the designs and the quantity of each design.

POSTER DELIVERY ADDRESSES

CBS Outdoor is not responsible for the delivery of your posters. Please contact CBS Outdoor Customer Service on 020 7482 3000 for the Poster Despatch Form.

CHANGES OF DESIGN

For campaigns lasting longer than 4 weeks a free, full or partial change of design will be provided during each succeeding 4 weeks.

Charges for more frequent changes of design are available on request.

Exact dates for changes of design are subject to posting cycle workload. Please contact CBS Outdoor Customer Service on 020 7482 3000 for more information.

DISPOSAL OF SPARE POSTERS

Please notify CBS Outdoor Customer Service in writing if you wish to retain spare posters after a campaign has ended. A small storage charge will be made. Otherwise posters will be disposed of 10 days after the campaign has ended.

CBS Outdoor, Camden Wharf, 28 Jamestown Road, Camden, London NW1 7BY.

COPY APPROVAL

Before posting can commence, every bus, rail and tram campaign must be submitted to CBS Outdoor for copy approval. This is to ensure that the Codes of Practice outlined by each of our franchise partners are being upheld.

To view the 'Codes of Practice and Guidelines' visit www.cbsoutdoor.co.uk. Go to the 'Customer Support' section and click on 'Copy Approval'.

To help in this process and to prevent unnecessary production costs, CBS Outdoor requires a colour copy of every design used in the campaign as soon as they are available. The colour copies must show the actual versions to be used in the campaign, be legible and show the entire poster.

The colour copies should be emailed to richard.ashman@cbsoutdoor.co.uk or sent to the following address:

CBS Outdoor
Camden Wharf
28 Jamestown Road
Camden
London NW1 7BY

Please mark them for the attention of Richard Ashman.

THIS ADDRESS IS FOR COPY APPROVALS ONLY
Do not send artworks or finished posters to this address

CBS Outdoor assures you of a swift response. Thank you for your co-operation.

Industry first

In 1999 CBS Outdoor introduced the first national, computerised barcoding system to monitor the bus medium. The system provides instant information about the posting of advertisers campaigns, bringing greater accountability to the medium.

More accountability

Barcoding gives advertisers accurate information about the fixing and location of their campaigns. The central computer is programmed to automatically verify information and constantly monitor the performance of each sign-fixing team.

Tracking of campaigns

The system consists of a hand-held scanner which the sign-fixers use to read the barcode on the poster and record the bus number. Every campaign has its own unique code. During posting the barcode is scanned and the bus number logged. The posting information is then down-loaded via modem to CBS Outdoor's database. The database compiles an accurate report of the posting, enabling CBS Outdoor to issue confirmation of posting details.

Fast and efficient

The system gives you fast, accurate information about your bus advertising campaign. It utilises the latest barcoding technology to monitor fixing of campaigns on CBS Outdoor's network of fleets. The process uses a fool-proof input system which only permits known site numbers to be input and removes the possibility of incorrect allocation.

Positioning your barcode

In order for the system to operate efficiently, barcodes must be placed in the bottom right-hand corner of all posters, 50mm from each edge as indicated in the examples below.

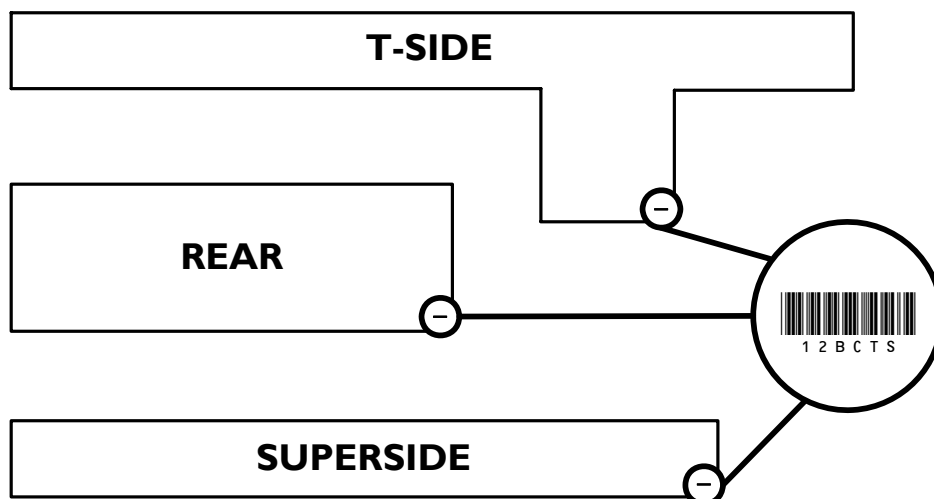

The barcode for each campaign can be provided at any time but will be issued automatically at the time of booking with the Confirmation of Order.

All CBS Outdoor bus and tram campaigns must be barcoded.

Should you have any questions or require further information, please contact either CBS Outdoor Customer Service or CBS Outdoor Production on 020 7482 3000.

The barcode

There are two ways of reproducing the barcode onto the poster:

1. The barcode can be treated as camera-ready artwork and 'shot' as a piece of film to be stripped into your full-size filmwork.
2. The barcode can be created on Apple Macintosh Software using a package called 'MacBarcoda', this produces a 'Code 39' type of barcode. Simply enter the number shown above the barcode and the software will create the barcode you require. This barcode can then be imported into your client's artwork document as an EPS or scan.

Different site types

CBS Outdoor will issue a different barcode for each site type you are printing. For example, if the campaign involves Supersides, Streetliners and Super Rears, you will receive three different barcodes. If you are producing different combinations of T-Sides i.e. Centre Stem, Off-Centre Stem and Forward Stem, the same barcode can be used for all three configurations.

Reprints

If you are reprinting posters used on a previous campaign, you do not require a new barcode, however, you must contact CBS Outdoor Customer Service on 020 7482 3000 and inform them of the barcode that you are printing.

Colours

Ideally the barcode should be printed in black or dark blue, if this is not possible another dark colour will suffice as long as it is printed onto a light-coloured background, this will enable the hand-held scanner to pick-up the contrast between the two colours. Never print the barcode in red as the scanner does not recognise any shade of red. Do not print the barcode in a dark colour on a dark background, if this situation arises create a white area, larger than the barcode, in the background colour or image and position the barcode accordingly.

Position

If printing the barcode in the position indicated interferes with your client's creative copy, feel free to re-position the barcode but please keep it 50mm from any edge and as near to the bottom right-hand corner as possible on all T-Sides and Supersides.

XL Bus Passenger Panels, Bus Passenger Panels (Portrait), Super Headliners and Bus Passenger Panels

These are smaller site types that are viewed at close quarters but will still require a barcode. To lessen the impact of the barcode you can print it at half the normal depth but do not alter the width. See the examples below.

Full size



Half depth



The barcode for each campaign can be provided at any time but will be issued automatically at the time of booking with the Confirmation of Order.

All CBS Outdoor bus and tram campaigns must be barcoded.

Should you have any questions or require further information, please contact either CBS Outdoor Customer Service or CBS Outdoor Production on 020 7482 3000.